

ELEVATION BREAKAWAY CABLE TERMINAL

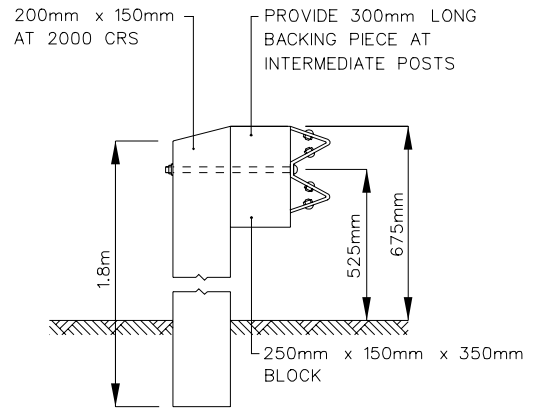

NOTE:-

Where specified the last 4.00m section of rail shall be factory bent to 10.50m radius (traffic face convex) to provide approximately 750mm set back on end post. Standard terminal ends shall be fitted. For fabrication and assembly of standard guardrails and handrails for highway bridges and bridge approaches see TNZ P/15P

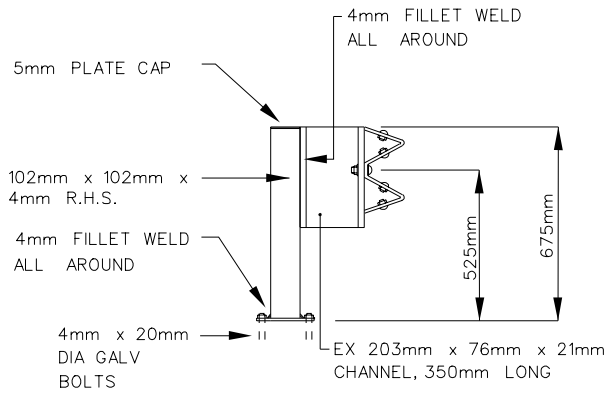
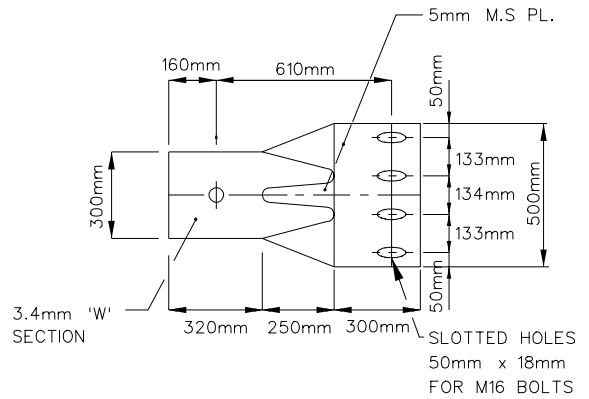

BRIDGE END POST



Head Office: 50 Centreway Road, Orewa
Private Bag 500, Orewa, 1461, New Zealand
Tel: 0800 4265169, Fax (09) 4267280
Email: info@rodney.govt.nz

26 February 2009

STANDARD DETAIL:

**ARMCO FLEXRAIL
FIXING DETAILS**

Copyright on this Drawing is Reserved

DATE: June 2005

NOT TO SCALE

RDC NO:

SHEET NO:

REV:

18000 3.23