

PLAN

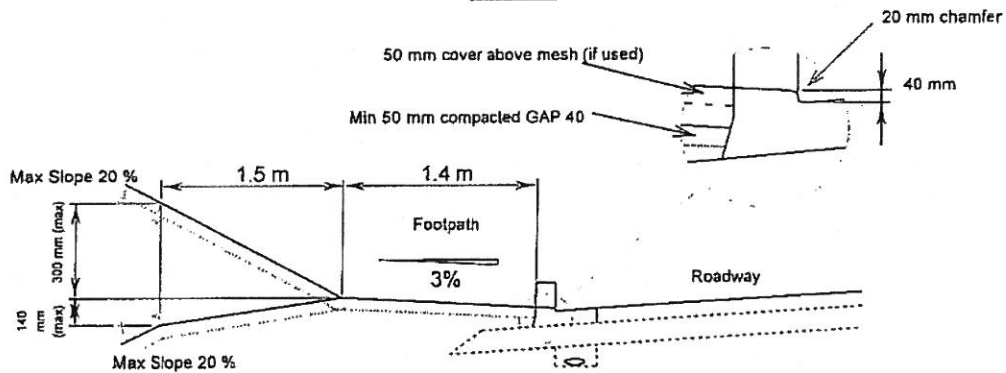

CROSS-SECTION

Notes

- 1 A Standard Urban Vehicle Crossing is an entrance to a Residential property in an urban area.
- 2 Concrete strength shall be 20 Mpa at 28 days (minimum).
- 3 Excavation shall be fenced and lit at night.
- 4 Existing concrete shall be saw cut at join and removed.
- 5 Brick or precast concrete paving units may be used only between the property boundary and the rear of the footpath. They shall comply with NZS 3116: 1981 Interlocking Concrete Paving.
- 6 Commercial vehicle crossing plan dimensions to be specifically designed (Refer FDC Standard Detail Drawing R7)
- 7 Residential vehicle crossing to be min. 150 mm thick. May be reduced to 110 mm thick if one layer of 665 mesh is used.
- 8 The Cross Sectional grades is designed to allow the 90 percentile vehicle to access the property without scraping underside of the vehicle.
- 9 The Minimum Distance between the Vehicle Crossing and the nearest Side Road Boundary is 7m on all roads with the exception of Arterial and State Highways (See Note 10 below).
- 10 Vehicle Crossings on Arterial Roads shall be located a minimum distance from road intersections and other vehicle crossings in accordance with Section 9.5 "Standards for the Location of Vehicle Crossings" in the Franklin District Plan (Refer FDC Standard Detail Drawing R 9).
- 11 The applicant shall be responsible for providing appropriate traffic control to safely undertake the construction of the vehicle crossing. This shall be undertaken in accordance with Transit New Zealands Code of Practice for Temporary Traffic Management.
- 12 The applicant shall be responsible for identifying any services in the area and the cost of any repairs to services damaged during construction of the vehicle crossing.
- 13 On-Street parking bays cannot be modified to form a vehicle crossing without the specific consent of the Franklin District Council.
- 14 Vehicle Crossings shall be located clear of any storm water cesspits.



Approved: 
 Date: February 2007
 No: R 4

STANDARD DETAIL
STANDARD URBAN VEHICLE CROSSING
(Footpath adjacent to Kerb)